

## Analysis & Design of High Rise Building Frames with TMD (Tuned Mass Damper)

Mr. Jitendra Ambule, Amey Khedikar 2

(M-Tech (Structure) Student, Department of Civil Engineering, Tulsiram Gaikwad-Patil College of Engineering and Technology, Wardha Road, Nagpur, Maharashtra-India)

<sup>2</sup>Asst. Prof., Civil Engineering Department, Tulsiramji Gaikwad Patil College of Engineering and Technology, Mohgaon, Nagpur, MH.

### Abstract

Earthquake is a compartment of structural analysis which involves the computation of the response of a structure subjected to earthquake excitation. This is required for carrying out the structural design, structural assessment and retrofitting of the structures in the regions where earthquakes are prevalent. Fast urbanization has led to construction of a large number of multistoried buildings. Buildings Safety from seismic point of view is important. Now a days number of tall buildings are going on increasing which are quite flexible and having very low damping value to minimize increasing space problems in urban areas. Base isolation techniques are quite effective. It requires insertion at foundation level which required constant maintenance. Active control techniques turn out to be costly as it requires continuous power supply. These structures should be designed to oppose dynamic forces through a combination of strength, flexibility and energy absorption such that it may deform beyond elastic limit when subjected to severe earthquake motion. To make these structures free from earthquake and wind induced structural vibration, various techniques has been adopted which can be broadly classified into 4 categories. (i) Active control, (ii) Passive control, (iii) Semi-active control and (iv) Hybrid control. The Soft storey will be made up of concrete and its columns , beams , slabs sizes will be smaller than other storeys of the building. TMD being made of concrete will have the same damping ratio as that of main building. For square columns TMD can be consider for square buildings.

**Key Words:** Tuned Mass Damper, Time history analysis, ETABS.

### I. Introduction

Now a days number of tall buildings are going on increasing which are quite flexible and having very low damping value to minimize increasing space problems in urban areas. Base isolation techniques are quite effective. It requires insertion at foundation level which required constant maintenance. Active control techniques turn out to be costly as it requires continuous power supply. These structures should be designed to oppose dynamic forces through a combination of strength, flexibility and energy absorption such that it may deform beyond elastic limit when subjected to severe earthquake motion. To make these structures free from earthquake and wind induced structural vibration, various techniques has been adopted which can be broadly classified into 4 categories. (i) Active control, (ii) Passive control, (iii) Semi-active control and (iv) Hybrid control.

The Soft storey will be made up of concrete and its columns , beams , slabs sizes will be smaller than other storeys of the building. TMD being made of concrete will have the same damping ratio as that of main building. For square columns TMD can be consider for square buildings.

### II. Submitting The Paper

The Full paper has to be submitted electronically by e-mail to the following addresses: **Network 1:** [icrtce@tgpcet.com](mailto:icrtce@tgpcet.com)

### III. Tuned Mass Damper Methodology

#### 3.1 Tuned Mass Damper

A tuned mass damper (TMD) is a device consisting of a mass, a spring, and a damper that is attached to a structure in order to reduce the dynamic response of the structure. The frequency of the damper is tuned to a particular structural frequency so that frequency is excited, the damper will resonate out of phase with the structural motion. Energy is dissipated by the damper inertia force acting on the structure. The Tuned Mass Damper (TMD) concept was first applied by Frahm in 1909 (Frahm, 1909) to reduce the rolling motion of ships as well as ship hull vibrations. A theory for the TMD was presented later in the paper by Ormondroyd and Den Hartog (1928), followed by a detailed discussion of optimal tuning and

damping parameters in Den Hartog's book on mechanical vibrations (1940). The natural frequency of the TMD is tuned in resonance with the fundamental mode of the primary structure, so that a large amount of the structural vibrating energy is transferred to the TMD and then dissipated by the damping as the primary structure is subjected to external disturbances. Consequently, the safety and habitability of the structure are greatly enhanced. From the field vibration measurements, it has been proved that a TMD is an effective and feasible system to use in structural vibration control against high earthquake loads, as shown in Figure 1.1.

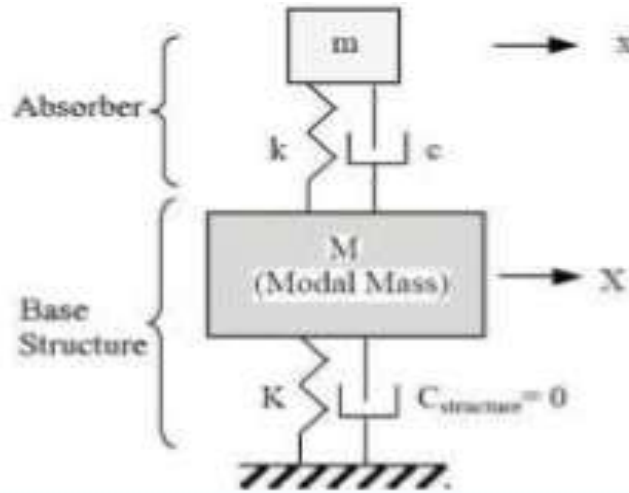

**Fig: 3.1** A schematic representation of damped vibration absorber suggested by Den Hartog

**BASIC PRINCIPLE**

Consider the response of single-degree-of-freedom (SDOF) structural system subjected to a vibratory force  $f(t)$  as shown in Figure

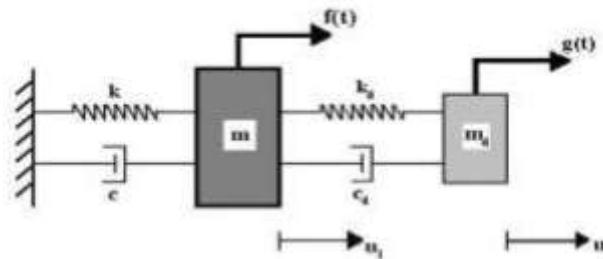

**Fig:** Model of SDOF structure and TMD

Referring to Figure the equations of motion are given as:

$$\begin{aligned}
 m\ddot{u}_1(t) + c\dot{u}_1(t) + ku_1(t) &= c_d[\dot{u}_2(t) - \dot{u}_1(t)] \\
 &+ k_d[u_2(t) - u_1(t)] + f(t), \\
 m_d[\ddot{u}_2(t) - \ddot{u}_1(t)] + c_d[\dot{u}_2(t) - \dot{u}_1(t)] \\
 &+ k_d[u_2(t) - u_1(t)] = -m_d\ddot{u}_1(t) + g(t),
 \end{aligned}$$

Where  $m$  is the main mass,  $m_d$  is the damper mass,  $k$  is the main spring stiffness,  $k_d$  is the absorber spring stiffness,  $c_d$  is the absorber damping,  $f(t)$  is the force acting on the main mass and  $g(t)$  is the force acting on the damper mass. Force acting on damper mass is given as:

$$g(t) = \begin{cases} \frac{m_d}{m} \cdot f(t) & \text{for earthquake loading} \\ 0 & \text{for wind excitation} \end{cases}$$

To facilitate further discussions, additional notations are introduced here as follows:  $\mu$  is the damper mass to the main mass ratio,  $\mu = m_d / m$ ,  $\omega$  is the frequency of a harmonic excitation,  $\omega_s$  is the natural frequency of the main mass,  $\omega_s^2 = k / m$ ,  $\omega_a$  is the natural frequency of the damper mass,  $\omega_a^2 = kd / m_d$ ,  $\beta$  is the ratio of excitation frequency to the main mass natural frequency,  $\beta = \omega / \omega_s$ ,  $\alpha$  is the frequency ratio,  $\alpha = \omega_a / \omega_s$ ,  $\xi_a$  is the damping ratio of TMD and  $\xi_s$  is the damping ratio of the main mass. Equation (1.1) (1.2) can be used for structural response analysis. These equations are valid, only for single-degree-of-freedom (SDOF) structural systems. Since most building structures are multi-degree-of-freedom systems (MDOF), a more general form of the equations of motion for a structure-TMD system, TMD is installed on top of the structure, for earthquake loading has the vector-matrix form.

$$m_d[\ddot{u}_2(t) - \ddot{u}_1(t)] + c_d[\dot{u}_2(t) - \dot{u}_1(t)] + k_d[u_2(t) - u_1(t)] = -m_d \frac{\varphi^T M r}{\varphi^T M \varphi} g(t),$$

Where  $\varphi$  represents the mode shape vector. Under wind-type loading, force acting on damper mass equals zero while for earthquake-type excitations,  $g(t)$  is the force acting on damper mass equals

$$g(t) = \left( \frac{\mu}{\Gamma} \right) \cdot f(t).$$

The participation factor ( $\Gamma$ ) is expressed as,

$$\Gamma = \frac{\varphi^T M r}{\varphi^T M \varphi}.$$

### 3.2 Damper System

Critical components of the TMD are the dampers themselves. Several types of dampers have been considered for use in TMD's. However, many of these types of dampers are not compatible with TMD's for tall buildings because they are unable to meet all the stringent requirements necessary for use in these applications. Typical requirements for the dampers include the following: 1. The damper(s) must obey the proper damping law (as a function of velocity, position, or both) over the appropriate environmental extremes in order to provide the proper level of added damping to the structure without shifting the ratio of natural frequency of the tuned mass to the natural frequency of the building itself. Recall that optimal TMD designs require a frequency ratio of 1:1 for periodic inputs. 2. System friction must be mitigated in order to maintain a functional TMD regardless of the level of excitation to the structure. 3. The dampers must be of a maintenance free design for several reasons: First and foremost, modern day tall buildings have a design life in the range of 50-100 years. Therefore, the TMD must also be designed for a long design life. Secondly, it is generally unacceptable to shut down operation of the TMD for an extended period of time for maintenance. Since maintenance of TMD's will typically take a period of at least several days, the peak accelerations may exceed acceptable levels during this time. 4. The damper(s) must be able to operate during extreme conditions. For the extreme event, such as the 500 year design storm, the damper will need to self adjust without relying on an external driving actuator, thereby effectively increasing the level of damping in order to limit the motions of the mass during the event.

### 3.3 CONCEPT:

The application of the Tuned Mass Damper (TMD) is an attractive option in reducing excessive floor vibrations. A TMD consists of a mass, spring, and dashpot, as shown in Figure 3.1, and is typically tuned to the natural frequency of the primary system. When large levels of motion occur, the TMD counteracts the movements of the structural system. The terms  $m_1, k_1, c_1, X_1$  represent the mass, stiffness, damping and displacement of the floor respectively, while  $m_2, k_2, c_2, X_2$  represent the mass, stiffness, damping and displacement of the TMD and  $F(t)$  represents the excitation force. As the two masses move relative to each other, the passive damper is stretched and compressed, reducing the vibrations of the structure through

increasing its effective damping. TMD systems are typically effective over a narrow frequency band and must be tuned to a particular natural frequency.

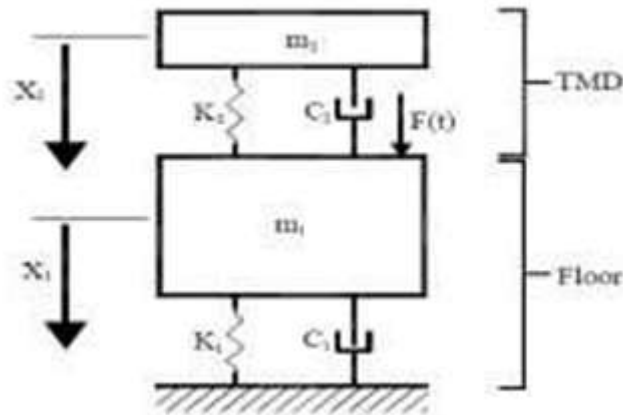

Fig. 3.3: Schematic Representation of a Two DOF System

Here, the subscript d refers to the tuned mass damper; as shown in Figure 3.2, the structure is idealized as a single degree of freedom system. Introduce the following notations.

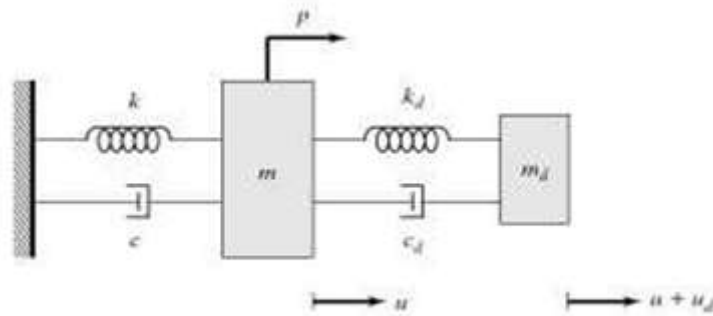

Fig. 3.4: SDOF-TMD system

$$(2.1) \quad \omega^2 = \frac{k}{m}$$

$$(2.2) \quad \bar{m} = \frac{m_d}{m}$$

and defining  $\bar{m}$  as the mass ratio, the governing equations of motion are given by

$$(2.3) \quad (1 + \bar{m})\ddot{u} + 2\xi\omega\dot{u} + \omega^2u = \frac{p}{m} - \bar{m}\ddot{u}_d$$

$$(2.4) \quad \ddot{u}_d + 2\xi_d\omega_d\dot{u}_d + \omega_d^2u_d = -\ddot{u}$$

The purpose of adding the mass damper is to limit the motion of the structure when it is subjected to a particular excitation. The design of the mass damper involves specifying the mass  $M_d$ , stiffness  $K_d$ , and damping coefficient  $C_d$ .

### 3.4 TUNED MASS DAMPER PARAMETERS

The natural frequency of the primary system can be divided into lower ( $f_1$ ) and higher ( $f_2$ ) frequency by attaching a spring mass tuned to the same fundamental natural frequency ( $f_n$ ) of the primary system as shown in Figure 3.2. The most significant design variable of the damper is the mass ratio ( $\mu$ ) as defined in equation 3.5. When the mass ratio increases, the TMD becomes more effective and robust. In most applications the mass ratio is designed to be in the range of 1-10%. In the design of a TMD, the optimum natural frequency of the damper ( $f_d$ ), and the optimum damping ratio of damper ( $\zeta_{opt}$ ) are given by equation (3.7) and (3.8) respectively.

(2.5)

$$f_d = \frac{f_n}{1 + \mu}$$

(2.6)

$$\zeta_{opt} = \sqrt{\frac{3\mu}{8(1 + \mu)^3}}$$

If there is zero damping then resonance occurs at the two un-damped resonant frequencies of the combined system ( $f_1$  &  $f_2$ ). The other extreme case was occurred when there is infinite damping, which has the effect of locking the spring ( $k_2$ ). In this case the system has one degree of freedom with stiffness of ( $k_1$ ) and a mass of ( $m_1 + m_2$ ). Using an intermediate value of damping such as  $\zeta_{opt}$ , somewhere between these extremes, it is possible to control the vibration of the primary system over a wider frequency range. The effectiveness of a single TMD was decreased significantly by the off-tuning or the off optimum damping in the TMD. The TMD damping ratio is also found to correspond approximately to the damping ratio computed for a SDOF system multiplied by  $\Phi$ , i.e.  $\zeta_{mdof}(\mu) = \Phi \zeta_{sdof}(\mu)$  and damping is given by equation (3.10).

(2.7)

$$f = \frac{1}{1 + \mu\Phi} \left[ 1 - \beta \sqrt{\frac{\mu\Phi}{1 + \mu\Phi}} \right]$$

(2.8)

$$\zeta = \Phi \left[ \frac{\beta}{1 + \mu} + \sqrt{\frac{\mu}{1 + \mu}} \right]$$

The above equation indicates that the best location for TMD is at the largest  $\zeta$ , i.e. at the level where  $\Phi$  and consequently the damping in the TMD and in the first two modes are maximums.

### 3.1 FORMULATION OF PRESENT WORK

Model I created considering plan dimension 21m X 21 m with 12 Storeys . Height of each floor is 3.1 m . Column size is 500 X 500 mm and beam size are 300 X 500 mm .The Model description is given in Table 3.1.Total height of building is 38.7 m. The 12 Storey model created without TMD first.

**Table 3.1 Model I: 12 Storey Building without TMD**

Plane dimensions	21x21 m
Total height of building	38.7 m
Height of each storey	3.1m
Height of parapet	1m
Depth of foundation	1.5m
Size of longitudinal beams	300x500 mm
Size of transverse beam	300 x 500 mm
size of columns	500x500 mm
thickness of slab	120 mm
Thickness of external walls	230 mm
Thickness of internal walls	115mm
Seismic zone	III
Soil condition	medium
Response reduction factor	5
Importance factor	1
Floor finishes	1.5kN/m <sup>2</sup>
Live load at all floors	3 kN/m <sup>2</sup>
Grade of Concrete	M25
Grade of Steel	Fe500
Density of Concrete	25 kN/m <sup>3</sup>
Density of brick masonry	20 kN/m <sup>3</sup>

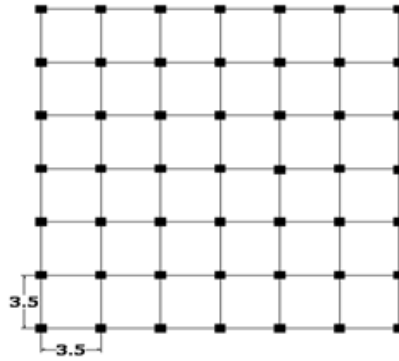

Fig. : Plan of building

The above figure shows the plan of 12 storied building as explain above without TMD

**Model II: 12 Storey Building with TMD**

Model II created considering plan dimension 21m X 21 m with 12 Storeys . Height of each floor is 3.1 m . Column size is 500 X 500 mm and beam size are 300 X 500 mm . The Model description is given in Table 3.1.Total height of building is 38.7 m. The 12 Storey model created with TMD.Model III created considering plan dimension 21m X 21 m with 14 Storeys. Height of each floor is 3.1 m . Column size is 500 X 500 mm and beam size are 300 X 500 mm . The Model description is given in Table 3.2. Total height of building is 44.9 m. The 14 Storey model created without TMD first.

**Table 3.2 Model III: 14Storey Building without TMD**

Plane dimensions	21x21 m
Total height of building	44.9 m
Height of each storey	3.1m
Height of parapet	1m
Depth of foundation	1.5m
Size of longitudinal beams	300x500 m
Size of transverse beam	300 x 500 mm
size of columns	600x600 mm
thickness of slab	120 mm
Thickness of external walls	230 mm
Thickness of internal walls	115mm
Seismic zone	III
Soil condition	Medium
Response reduction factor	5
Importance factor	1
Floor finishes	1.5kN/m <sup>2</sup>
Live load at all floors	3 kN/m <sup>2</sup>
Grade of Concrete	M25
Grade of Steel	Fe500
Density of Concrete	25 kN/m <sup>3</sup>
Density of brick masonry	20 kN/m <sup>3</sup>

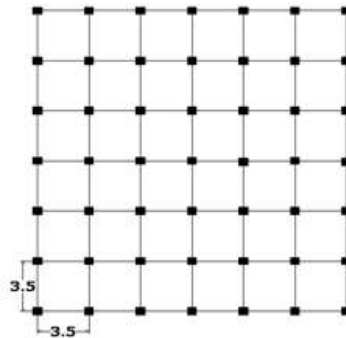

Fig. : Plan of building

The above figure shows the plan of 14 storied building as explain above without TMD

**Model IV: 14 Storey Building with TMD**

Model IV created considering plan dimension 21m X 21 m with 14 Storeys. Height of each floor is 3.1 m . Column size is 500 X 500 mm and beam size are 300 X 500 mm . The Model description is given in Table 3.2. Total height of building is 44.9 m. The 14 Storey model created with TMD .

Model V created considering plan dimension 21m X 21 m with 16 Storeys. Height of each floor is 3.1 m . Column size is 500 X 500 mm and beam size are 300 X 500 mm . The Model description is given in Table 3.3. Total height of building is 51.1 m. The 16 Storey model created without TMD first.

**Table 3.3 Model V: 16Storey Building without TMD**

Plane dimensions	21x21 m
Total height of building	51.1 m
Height of each storey	3.1m
Height of parapet	1m
Depth of foundation	1.5m
Size of longitudinal beams	300x500 m
Size of transverse beam	300 x 500 mm
size of columns	600x600 mm
thickness of slab	120 mm
Thickness of external walls	230 mm
Thickness of internal walls	115mm
Seismic zone	III
Soil condition	medium
Response reduction factor	5
Importance factor	1
Floor finishes	1.5kN/m <sup>2</sup>
Live load at all floors	3 kN/m <sup>2</sup>
Grade of Concrete	M25
Grade of Steel	Fe500
Density of Concrete	25 kN/m <sup>3</sup>
Density of brick masonry	20 kN/m <sup>3</sup>

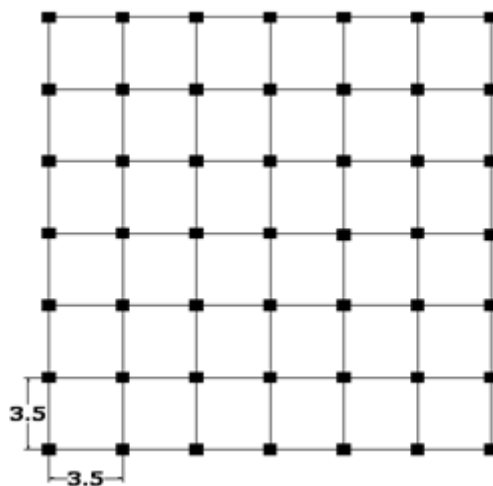

**Fig.:** Plan of building

The above figure shows the plan of 16 storied building as explain above without TMD

**Model VI: 16Storey Building with TMD**

Model VI created considering plan dimension 21m X 21 m with 16 Storeys. Height of each floor is 3.1 m . Column size is 500 X 500 mm and beam size are 300 X 500 mm . The Model description is given in Table 3.3. Total height of building is 51.1 m. The 16 Storey model created with TMD .

Modelling will be done in ETABS and response spectrum analysis will be performed on all models.

**3. Storey Drift**

It is seen that the storey drift values are slightly high for the top floor while using TMDs 5% for X – direction excitation and Y-direction excitation respectively. In the case of a symmetrical building the storey



height is 3.1 m and base storey height is 1.5m. According to the storey drift limitation given in IS 1893(Part I): 2002 each storey drifts must be limited to 0.004 times the storey height. The results shows 12 storey model has storeydrift of 0.5 mm without TMD and 0.2 mm with TMD. The results shows 16 storey model has storeydrift of 0.6 mm without TMD and 1.6 mm with TMD.

### Storey Drift In Mm

Table shows the subsequent storey drifts for various floors in mm

Storey	Without TMD	With TMD
Story16	0.6	1.6
Story15	0.8	0.6
Story14	1.1	0.4
Story13	1.3	0.8
Story12	1.5	1.1
Story11	1.7	0.9
Story10	1.9	0.9
Story9	2.1	1.2
Story8	2.2	1.1
Story7	2.3	0.9
Story6	2.5	0.7
Story5	2.6	1.0
Story4	2.7	0.9
Story3	2.9	0.6
Story2	3	0.8
Story1	4.6	1.2

In this chapter an extensive study on seismic response of building fitted with a very simple type of TMD is presented. This TMD is in the form of soft storey at building top is considered. This soft storey is over the entire plan area of building with , columns & Slab . Its column and beam sizes are smaller than column and beam sizes of building. This soft storey is tuned in such a way that its natural frequency bears an optimum frequency ratio with the natural frequency of building. Mass of this soft storey is in the range of 2 to 5 % of the mass of the building. This soft storey has rectangular columns with nearly same b/D ratio as that of building columns. StoreyDrift It is seen that the storey drift values are slightly high for the top floor while using TMDs 5% for X – direction excitation and Y-direction excitation respectively. In the case of a symmetrical MRF building the storey height is 3m and base storey height is 1.5m. According to the storey drift limitation given in IS 1893 (Part I): 2002 each storey drifts must be limited to 0.004 times the storey height. Time histories for displacement at building top are shown. These results are for rectangular building subjected to earthquake in both lateral direction ie. X-direction and Y-direction. Results of square shape buildings are given for square shape top building displacement. In X & Y dir are same. 4.5 % TMD is found to be consistently effective in reusing the response of building. In this chapter, weak storey as a TMD gives encouraging results.

### IV. Conclusion:

The seismic behaviour of 10th, 12th, 14th, 16th storey building with tuned mass damper and without tuned mass damper was investigated. TMD is effective in reducing displacement and acceleration and, thereby, can be used for structures under earthquake. This study is aimed as tuned mass dampers in reducing structural (storey drift, storey displacement and base shear) of seismically excited 10th, 12th, 14th, 16th storey building. 1. It has been found that the TMDs can be successfully used to control vibration of the structure. 2. For the regular building frame, 5% TMD is found to effectively reduce top storey displacement. The reduction of 10th storey building is 38.13, reduction of 12th top storey building is 36.36, reduction of 14th top storey building is 35.16, reduction of 16th top storey building is 33.34. And base shear by about 2%. 3. Therefore, the TMD should be placed at top floor for best control of the first mode. 4. For the regular building, TMD with damping exponent (n) value 0.2 is found to be better than TMD with damping exponent value 0.5. 5. From analysis it can be seen that it is necessary to properly implement and construct a damper in any high rise building situated in earthquake prone areas.

1. The values of displacement and drift are found to be more on structure when structure is acted upon by dynamic conditions without damper.
2. But by assigning Tuned Mass Damper to structure, the structure is going to more stable as the values of displacement and drift are reduced.
3. The acceleration also reduced significantly using tuned mass damper.
4. From the analysis and observations of graph we can conclude that , the percentage decrease in the displacement and drift values found to be reduced by 28% and 32% respectively.



5. Therefore the Tuned Mass Damper is highly useful in tall Structure as it is resist the structures motions under the dynamic conditions.
6. Seismic performance of building after application of damper is much better when we provide to top of storey.
7. It has been found that the TMD can be successfully used to control vibration of the structure.
8. For story drift which is important behavior for finishes such as sliding windows, performance is better for building with TMD.
9. Application of TMD damper reduces large amount of displacement of the structure.
10. Due to absolute displacement reduction the structure have not require more ductility to resisting earth-quake forces.
11. With the using of TMD in the structure, the base shear slightly increases.
12. With the using of TMD in the structure, the Fundamental Period of structure reduces.

#### **V. Suggested Further Work:**

In future the study of the seismic behaviour of 18th, 21th, 23th, 25th storey building with tuned mass damper and without tuned mass damper may be investigated. TMD is effective in reducing displacement and acceleration and, thereby, can be used for structures under earthquake. This study is aimed as tuned mass dampers in reducing structural (storey drift, storey displacement and base shear) of seismically excited 18th, 21th, 23th, 25th storey building.

#### **References**

- [1]. McNamara RJ. Tuned mass dampers for buildings. *Journal of the Structural Division, ASCE* 1977;103(ST9):1785–98.
- [2]. Jangid RS. Dynamic characteristics of structures with multiple tuned mass dampers. *Structural Engineering and Mechanics* 1995;3:497–509.
- [3]. Lin CC, Ueng JM, Wang JF. Vibration control identification of MDOF structures with tuned mass damper. *International Conference on Structural Dynamics, Vibration, Noise and Control, Hong Kong* 1995;2:887–94.
- [4]. Luft RW. Optimal tuned mass dampers for buildings. *Journal of the Structure Division, ASCE* 1979;105:2766–72.
- [5]. Frahm H. Device for damping vibration of bodies. U.S. Patent No.989-958; 1911.
- [6]. Seismic response reduction of irregular buildings using passive tuned mass dampers, Chi-Chang Lin.
- [7]. Increase of a high rise buildings damping behavior by applying large Scale Tuned Mass Dampers Christian MEINHARDT Dr. -Ing Project Engineer GERB Vibration Control Systems Essen, Germany.
- [8]. Optimal design theories and applications of tuned mass dampers, Chien-Liang Lee.
- [9]. Rana R, Soong TT. Parametric study and simplified design of tuned mass dampers. *Engineering Structures* 1998;20:193–204.
- [10]. Li C, Liu Y. Optimal multiple tuned mass dampers under the ground acceleration based on the uniform distribution of system parameters. *Earthquake Engineering and Structural Dynamics* 2003;32: 671–90.
- [11]. V.M. Thakur, and P.D. Pachpor, Seismic Analysis of Multi-storeyed Building with TMD (Tuned Mass Damper), *International Journal of Engineering Research and Applications*, Vol. 2, Issue 1, 2012, 319-326.